

Bambu Lab A2L AMS Combo

Quick Start Guide

Please review the entire guide before using the product.

Safety notice: Do not connect to power until the assembly is complete.

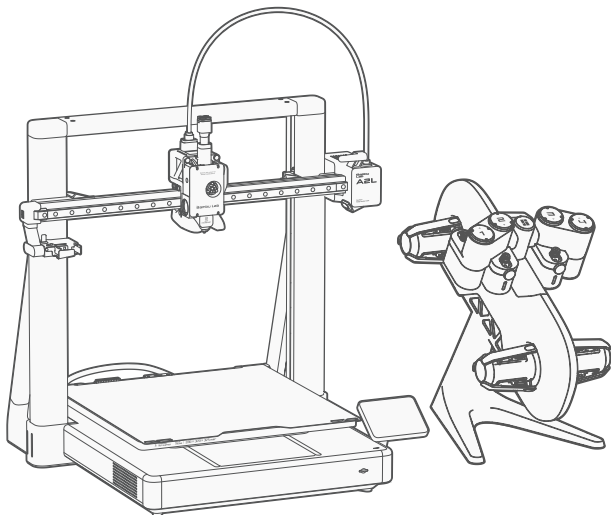



Video Guide

Watch a step-by-step video and get started quickly.

bambulab.com/a2l-combo-quick-start



Download Bambu Handy and Bambu Studio

Remotely control your printer and monitor your prints in real time on both your phone and computer.

bambulab.com/download



Explore More Cool Models

Visit MakerWorld, our models community, to find a variety of free models and bring your ideas to life using the creativity tools in MakerLab and accessories in Maker's Supply.

makerworld.com



Learn with Bambu Academy

Visit Bambu Academy and explore printer and software courses from beginner to advanced levels to enhance your 3D printing skills.

bambulab.com/support/academy

Table of Contents

1. Read Before Use.....	4
2. Printer Component Introduction.....	5
3. Toolhead Component Introduction.....	7
4. AMS lite Component Introduction.....	8
5. Included Accessories.....	9
6. Remove the Package.....	11
7. Secure the Heatbed.....	14
8. Assemble the Base Housing and Frame.....	15
9. Remove the Y-Axis Top Cover.....	17
10. Secure the Base Housing.....	19
11. Lubricate the Y-Axis Guide Rail.....	20
12. Install the Y-Axis Top Cover.....	21
13. Connect the Z-Axis Motor Cable.....	22
14. Connect the Integrated Cable.....	23
15. Remove Z-Axis Limiters.....	24
16. Install the Purge Wiper.....	25
17. Fold Out the Touchscreen.....	28

Table of Contents

18. Install the Build Plate.....	29
19. Assemble AMS lite.....	30
20. Use Other AMS.....	34
21. Install the External Spool (for Non-AMS Use Case).....	35
22. Plug in the Power Cable and Power On.....	36
23. Network Setting.....	37
24. Bind the Printer - Bambu Handy.....	38
25. Bind the Printer - Bambu Studio.....	39
26. Load Filament Spool on AMS lite.....	40
27. First Print.....	42
28. After-Print Notes.....	43
29. Regular Maintenance.....	44
30. Printer Specifications.....	45
31. AMS lite Specifications.....	48
32. Technical Support.....	49

1. Read Before Use



To ensure safety and optimal performance, please follow these guidelines:

- Verify that the printer's operating voltage matches the specified requirements to avoid damage or safety hazards. This can be checked on the label next to the power socket. Refer to the "Printer Specifications" section for details.
- The heatbed moves back and forth during operation. Ensure adequate clearance in front of and behind the printer to allow proper operation.
- During operation, keep hands and other body parts clear of the heatbed's range of motion to avoid collisions or burns.
- Regular maintenance is essential to keep the printer's complex mechanisms running smoothly. For guidance, see the "Regular Maintenance" section.
- For best results, we recommend using Bambu filaments, which have been rigorously tested for compatibility, safety, and stability with the product.
- **To prevent the filament from getting stuck, do not use flexible filaments such as TPU with a hardness level of 95A or lower, or damp PVA and BVOH, in the AMS lite.**
- **To prevent wear of the filament feed path, do not use PLA Glow or third-party fiber-reinforced filaments such as CF or GF with the AMS lite.**
- Avoid excessive bending or overly long PTFE tubes, as this can lead to filament feeding issues.
- The AMS lite supports spools with a width of 40-68 mm and an inner diameter of 53-58 mm.

2. Printer Component Introduction

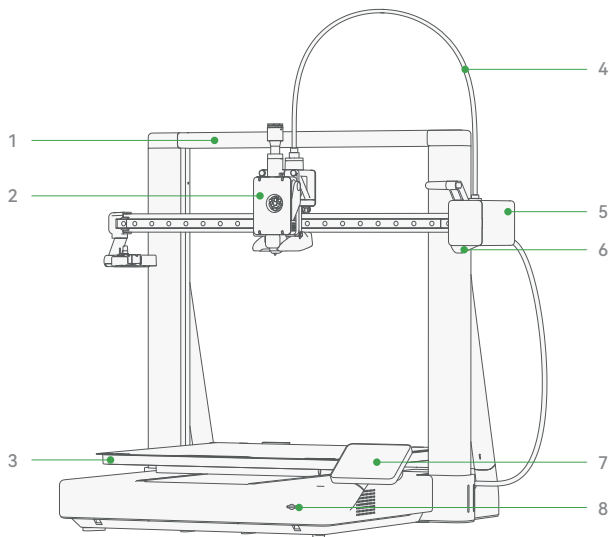

Figure 1

- 1) Printer Frame
- 2) Toolhead
- 3) Heatbed
- 4) Toolhead Cable

- 5) X-Axis Motor Cover
- 6) Camera
- 7) Touchscreen
- 8) MicroSD Card

2. Printer Component Introduction

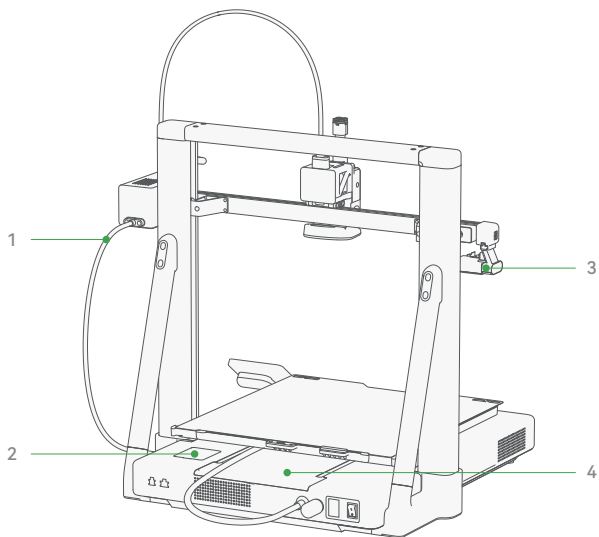
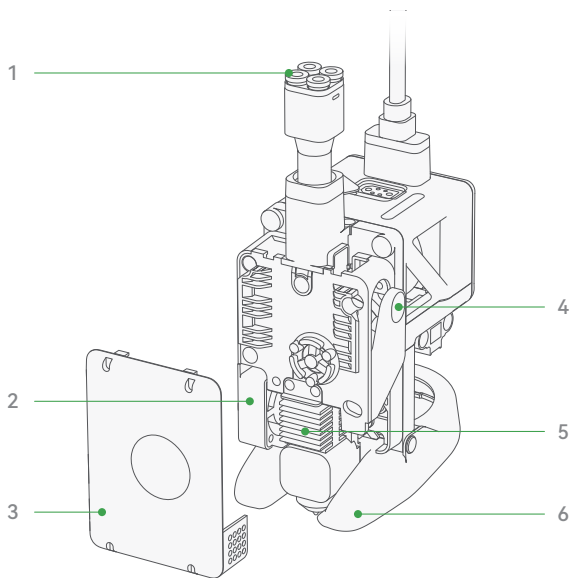

Figure 2

- 1) Integrated Cable
- 2) Z-Axis Motor Cover

- 3) Purge Wiper
- 4) Y-Axis Top Cover

3. Toolhead Component Introduction



1) Toolhead Filament Inlet

2) Hotend Cooling Fan

3) Toolhead Front Cover

4) Filament Cutter Lever

5) Hotend

6) Part Cooling Fan

4. AMS lite Component Introduction

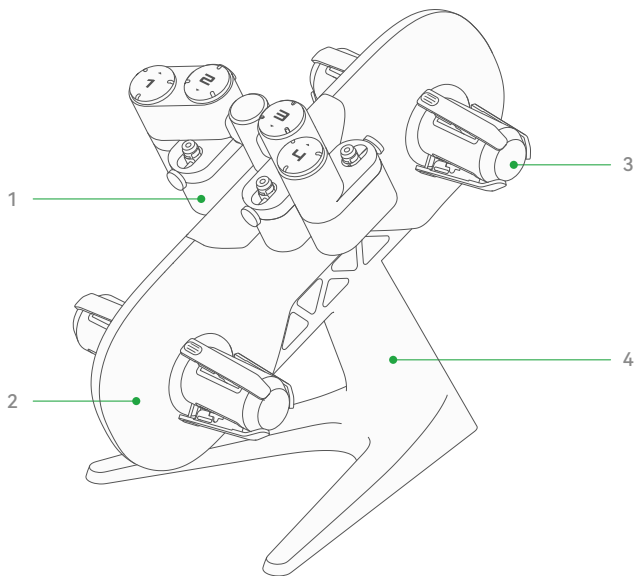

1) Filament Funnel Unit

2) AMS lite Body

3) Rotary Spool Holder

4) AMS lite Stand

5. Included Accessories

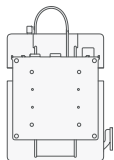

1) A2L Base Housing

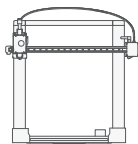

2) A2L Printer Frame

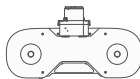

3) AMS lite Body



4) AMS lite Stand

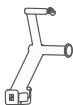

5) Spool Holder



6) AMS lite Rotary Spool Holder



7) Purge Wiper



8) Power Cable



9) Build Plate



10) Unlogging Pin



11) Scraper Blade



12) Filament Cutter



13) PTFE Tube Coupler



14) Z-Axis Motor Cover



15) Silicone Footpad



16) Foam Footpad

5. Included Accessories



17) PTFE Tubes
for AMS lite
(PTFE Tube Silicone
Clamp Included)



18) PTFE Tube



19) Sample Filament



20) Allen Key H1.5
Allen Key H2.0

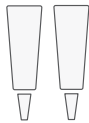

21) Lubricant Grease
& Lubricant Oil

6. Remove the Package Keep packaging materials and screws for shipping.

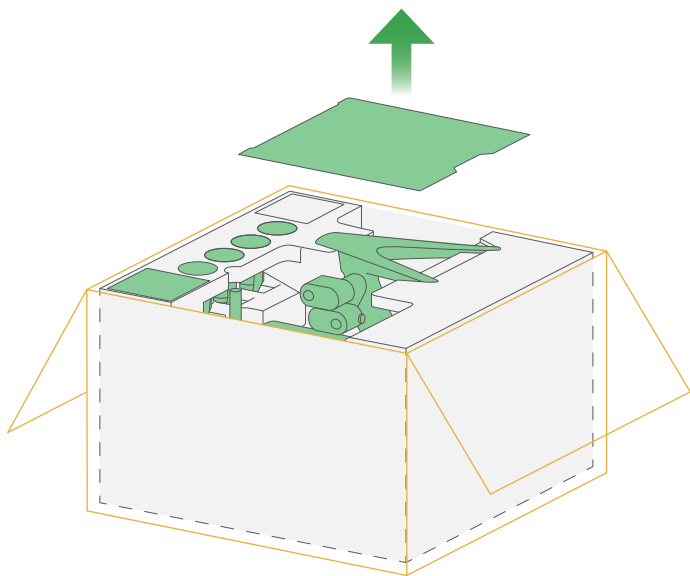

- 1) Open the package box, tear open the moisture-proof bag, and remove all accessories one by one, including those embedded in the foam, placing them neatly aside.

Warning: When removing the base housing, support it with both hands from the left and right sides and lift it out. Do not pull it out by the zip ties.

6. Remove the Package

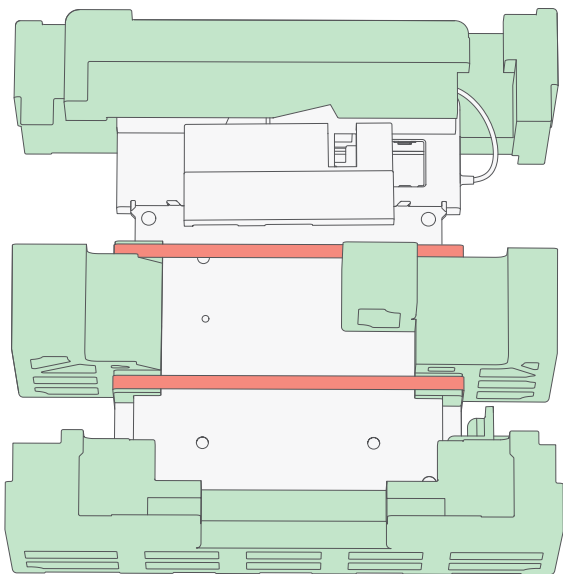

- 2) Place the base housing on a flat surface.
- 3) Cut the zip ties and remove the foam marked in green around the base housing.

6. Remove the Package

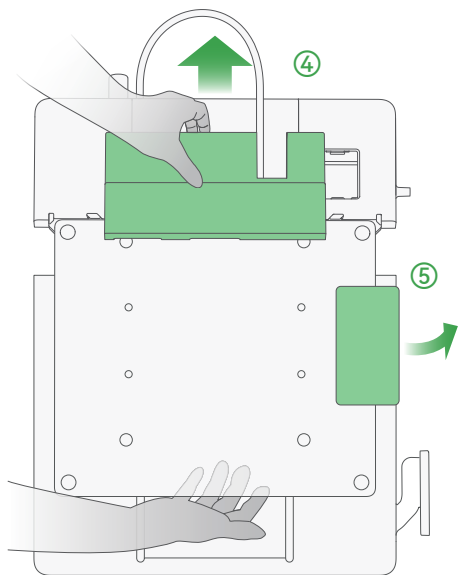

- 4) Hold the heatbed with your hand and remove the foam behind the heatbed.
- 5) Read the warning label carefully, then remove it from the heatbed.

7. Secure the Heatbed

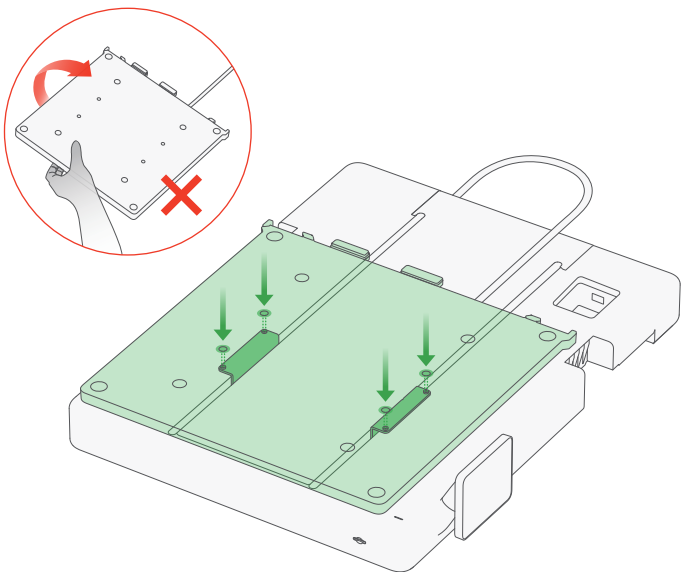

Align the screw holes on the heatbed with those on the Y-axis carriage, then use an H2.0 allen key to install and tighten the 4 screws for heatbed to secure it.

Warning: Do not flip the heatbed during installation. Ensure the cable is not twisted. Align the mounting holes and place the heatbed in position in one motion. Avoid sliding or repeated movement.

8. Assemble the Base Housing and Frame

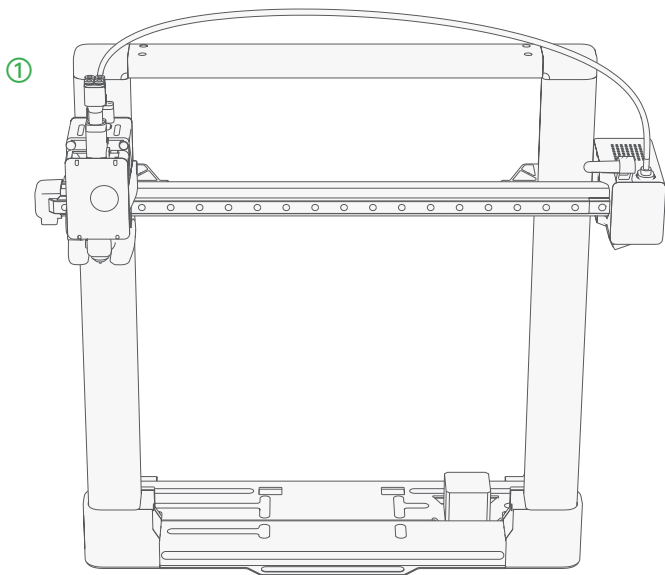

- 1) As shown in the image, place the frame vertically on the table with the toolhead facing you.

8. Assemble the Base Housing and Frame

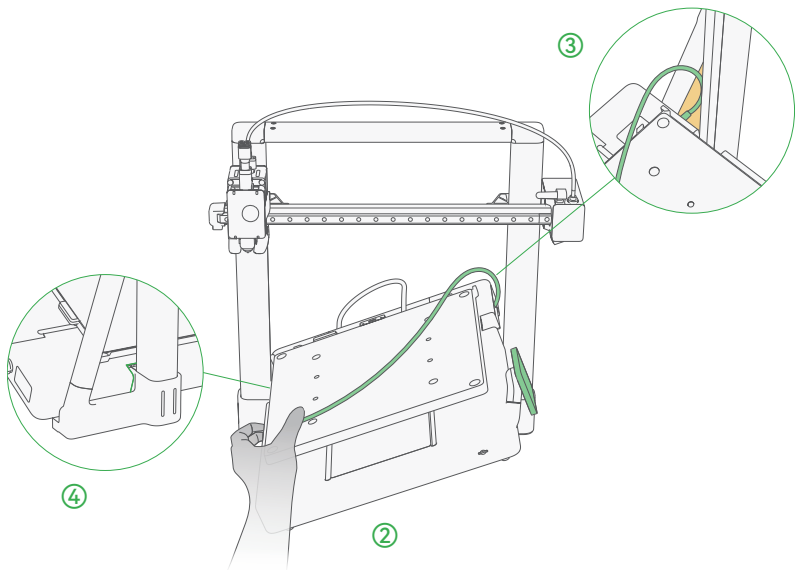

- 2) Hold the integrated cable and tilt the base housing about 45° to pass it through the frame.
- 3) Aim the integrated cable at the triangular gap. Ensure it does not touch other components.
- 4) Align the slot with the frame. Slowly lower the base housing until it is flush with the frame.

Note: If you encounter any operational issues, please refer to the video guide.

9. Remove the Y-Axis Top Cover

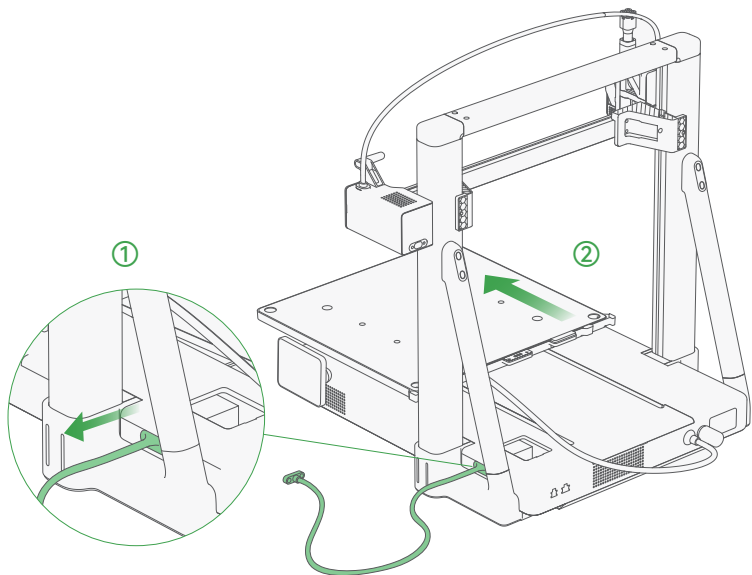

- 1) Pass the integrated cable through the triangular gap of the frame and place it neatly aside.
- 2) Push the heatedbed fully to the front end.

9. Remove the Y-Axis Top Cover

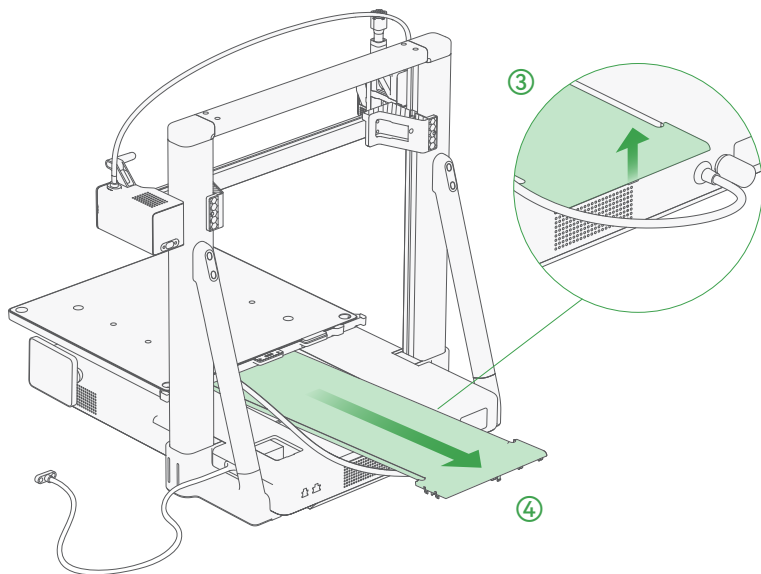

- 3) Lift the rear end of the Y-axis top cover upwards.
- 4) Gently pull out the Y-axis top cover.

10. Secure the Base Housing

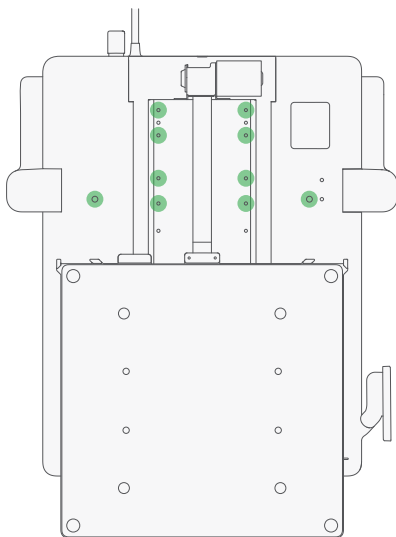

Take the 10 screws for the base housing from the accessory box, and use the H2.0 wrench to install them into the green-marked holes. Tighten them fully to ensure the base is securely fixed.

Note: Make sure the screws are fully tightened. Otherwise, the Y-axis may not move properly or may lose steps. If either of these issues occurs, first check whether the screws have been tightened securely.

11. Lubricate the Y-Axis Guide Rail

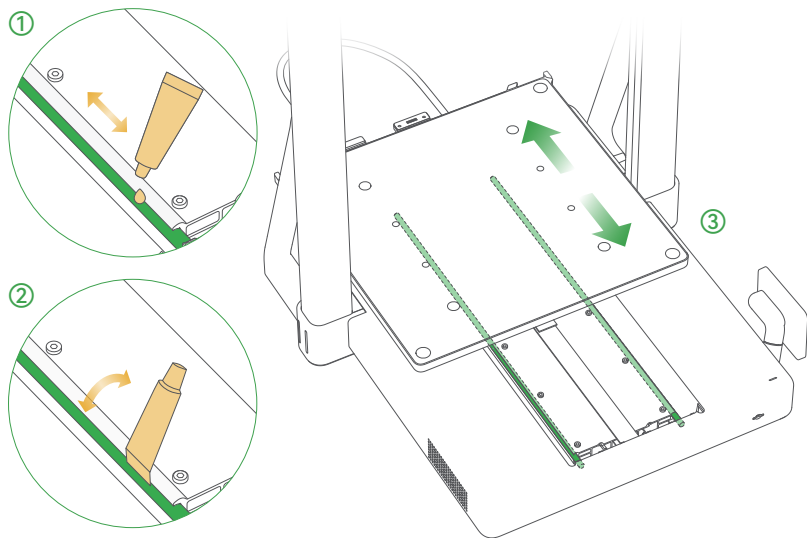

- 1) Take the lubricant oil from the accessory box and apply a small amount along the top edge of the Y-axis guide rail.
- 2) Use the end of the lubricant oil to evenly spread it over the curved surface of the rail.
- 3) Move the heatbed back and forth to distribute the lubricant oil evenly.

Warning: Do not use lubricant grease. Use lubricant oil only.

Note: If you encounter any operational issues, please refer to the video guide.

12. Install the Y-Axis Top Cover

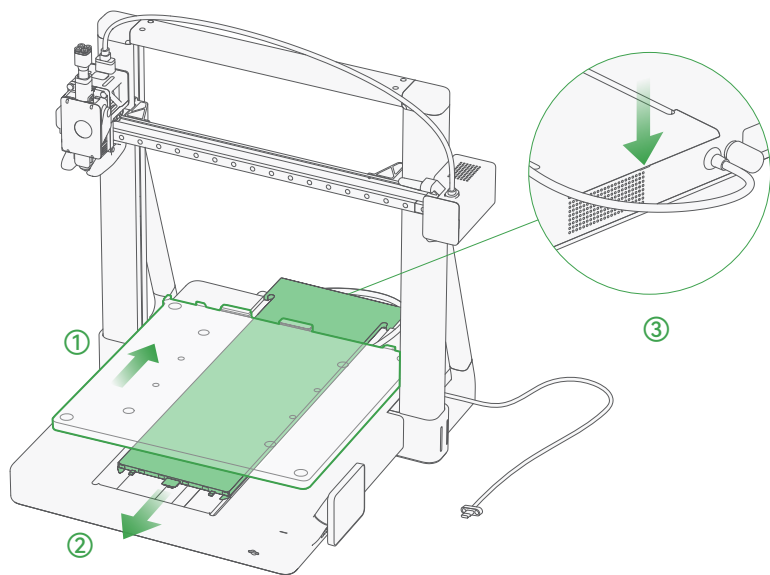

- 1) Push the heatbed to the middle.
- 2) Align the front-end latch of the Y-axis top cover with the mounting slot and gently slide it into place.
- 3) Press down on the rear end of the Y-axis top cover to ensure the latch is completely clipped in place.

13. Connect the Z-Axis Motor Cable

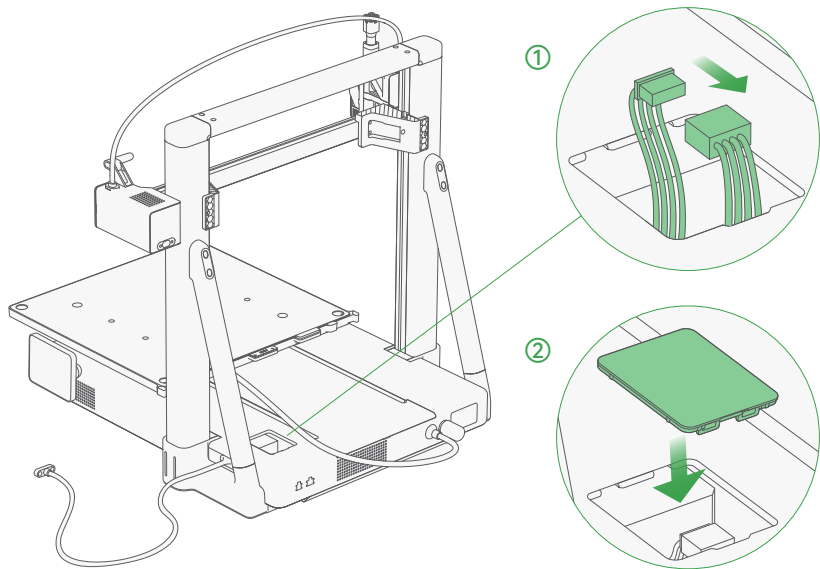

- 1) Connect the Z-axis motor cable as shown.
- 2) Take the Z-axis motor cover from the accessory box and install it in place.

14. Connect the Integrated Cable

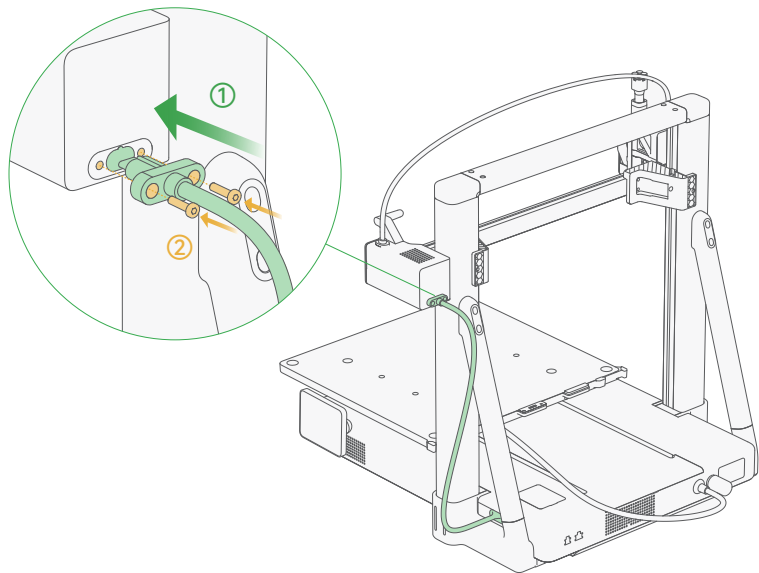

- 1) Insert the integrated cable into the back of the X-axis motor cover as shown.
- 2) Use the H2.0 allen key to tighten the 2 screws for integrated cable to secure it.

Warning: Ensure the integrated cable is not twisted.

15. Remove Z-Axis Limiters

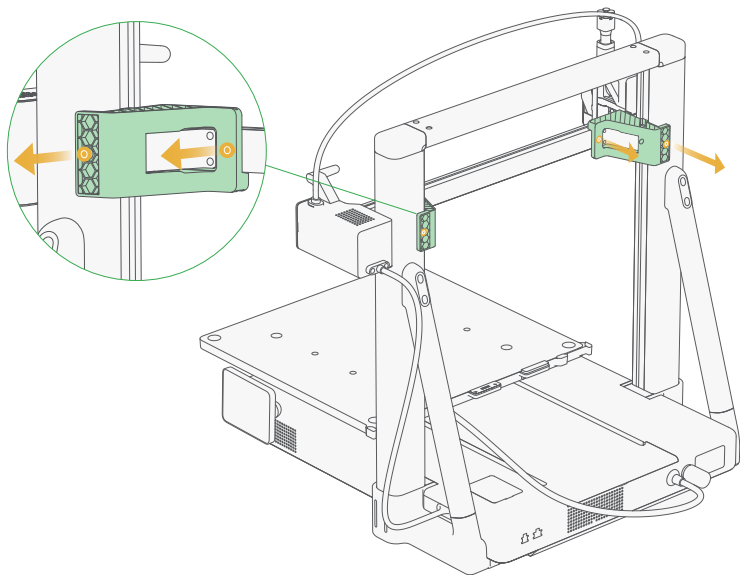

- 1) Use the H2.0 allen key to loosen 4 screws and then remove the 2 Z-axis limiters.
- 2) Remove all tapes from the toolhead and the X-axis motor cover.

16. Install the Purge Wiper

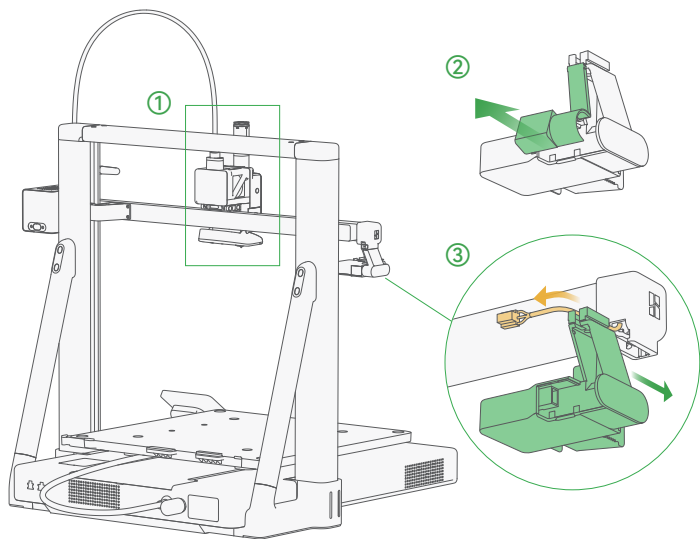

- 1) Manually move the toolhead to the middle of the rail to reserve enough space for installing the purge wiper.
- 2) Take the purge wiper from the accessories and open its rear cover.
- 3) Pull the hall sensor cable at the X-axis end cap forward to prevent it from getting caught, then slide the purge wiper into the X-axis end slot.

Note: If you encounter any operational issues, please refer to the video guide.

16. Install the Purge Wiper

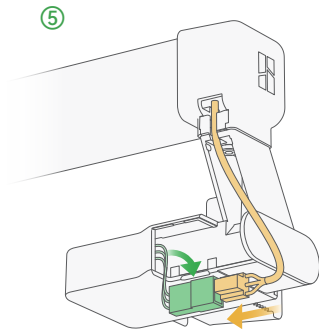
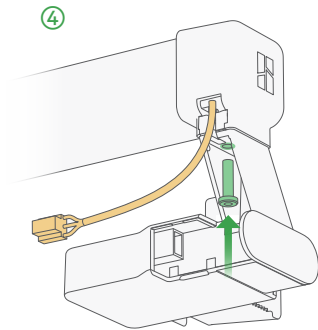

- 4) Take 1 screw for the purge wiper from the accessory box. Use the H2.0 Allen key to tighten it and secure the purge wiper.
- 5) Connect the hall sensor cable to the purge wiper connector.

16. Install the Purge Wiper

6

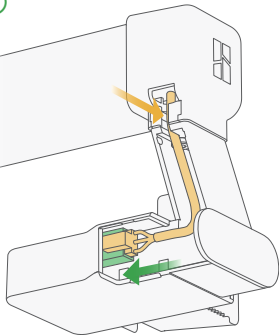

7

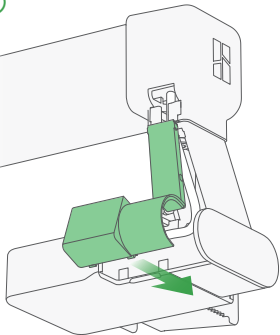

- 6) Press the cable in the slot, and align the connectors to the left. Ensure the cables stay clear of the rear cover installation area.
- 7) Install the rear cover of the purge wiper.

17. Fold Out the Touchscreen

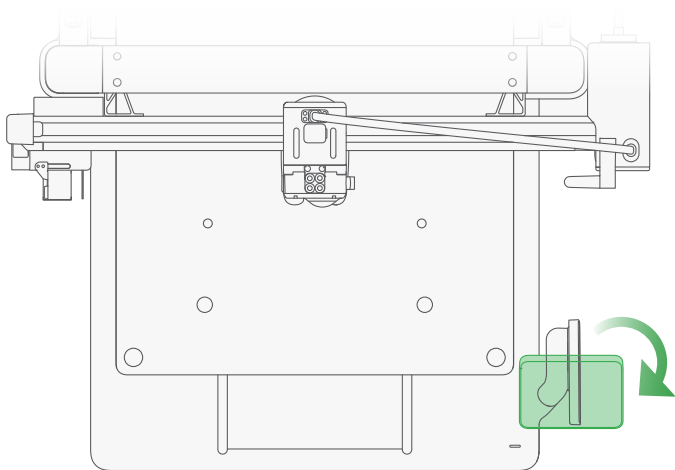

Fold out the touchscreen. Make sure the touchscreen is in place as shown in the graph.

18. Install the Build Plate

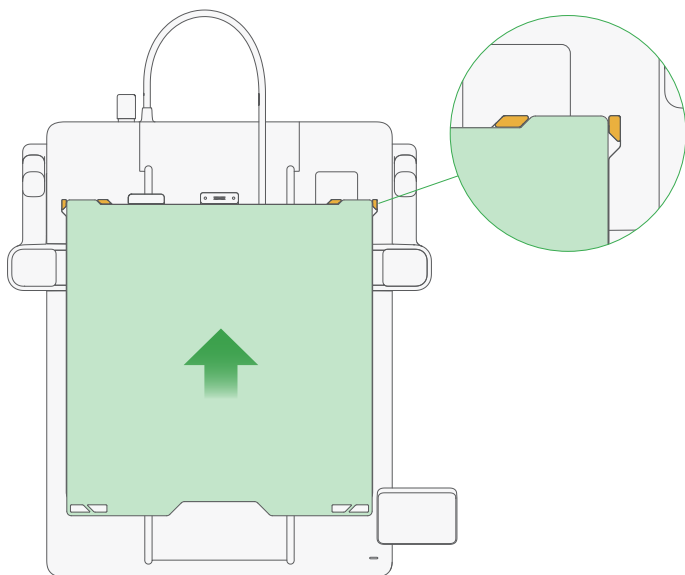

Install the build plate in the correct orientation, aligning its edges with the heated bed.

Warning: Improper alignment of the build plate may scratch the touchscreen.

Note: If you have touched the surface of the build plate with your hands, we recommend washing it with hot water and detergent for the best adhesion properties.

19. Assemble AMS lite

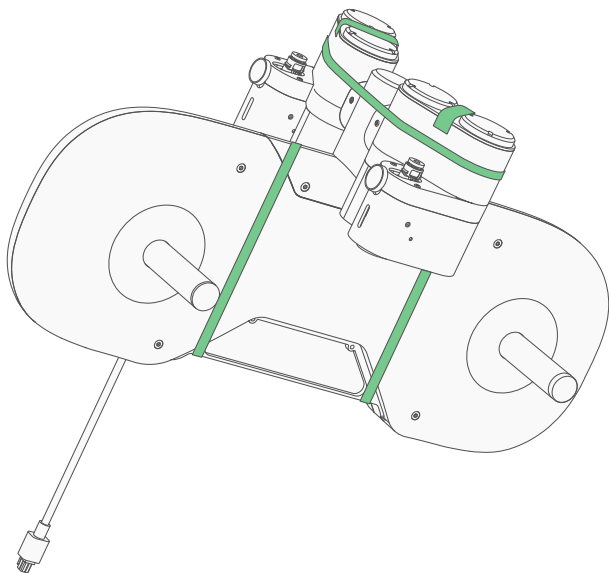

- 1) Remove all zip ties and tapes marked in green from the AMS lite body.

19. Assemble AMS lite

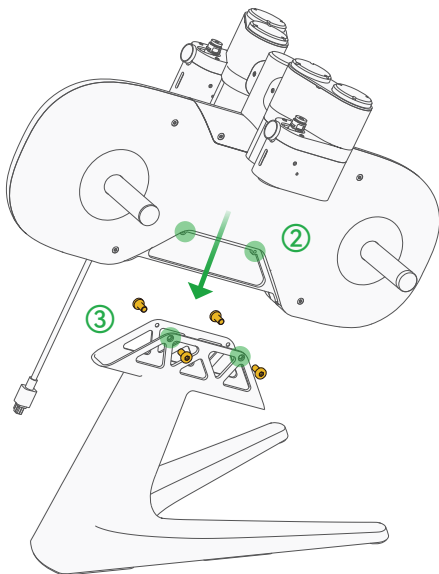

- 2) As shown in the figure, place the AMS lite body on the stand, ensuring the cable end is oriented correctly.
- 3) Use H2.0 allen key to tighten 4 screws for AMS stand from the accessory box to secure the AMS lite.

19. Assemble AMS lite

4

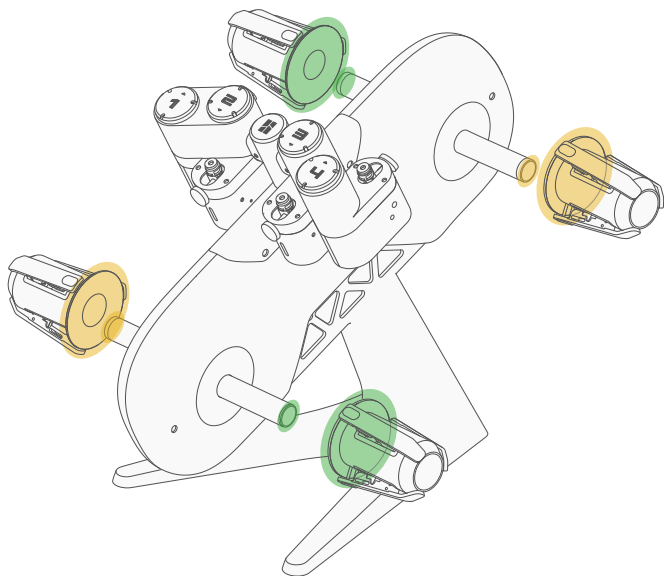

- 4) Fully slide in the rotary spool holders, ensuring the colors are matched to prevent any damage.

19. Assemble AMS lite

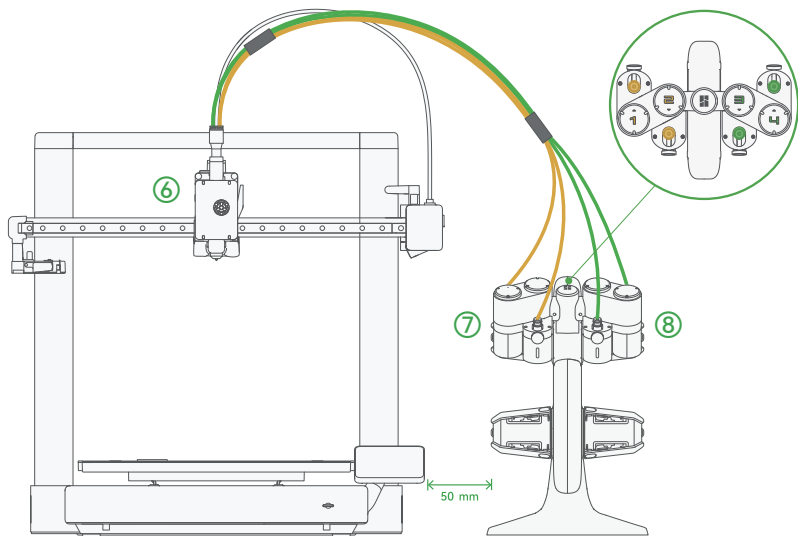

- 5) Place the AMS lite to the right side of the A2L.
- 6) Insert the 4 PTFE tubes, ensuring their ends are flush, into the toolhead filament inlet.
- 7) Insert the short PTFE tubes into ports 1 and 2.
- 8) Insert the long PTFE tubes into ports 3 and 4.

(The recommended distance between A2L and AMS lite is 50 mm as shown in the diagram.)

20. Use Other AMS

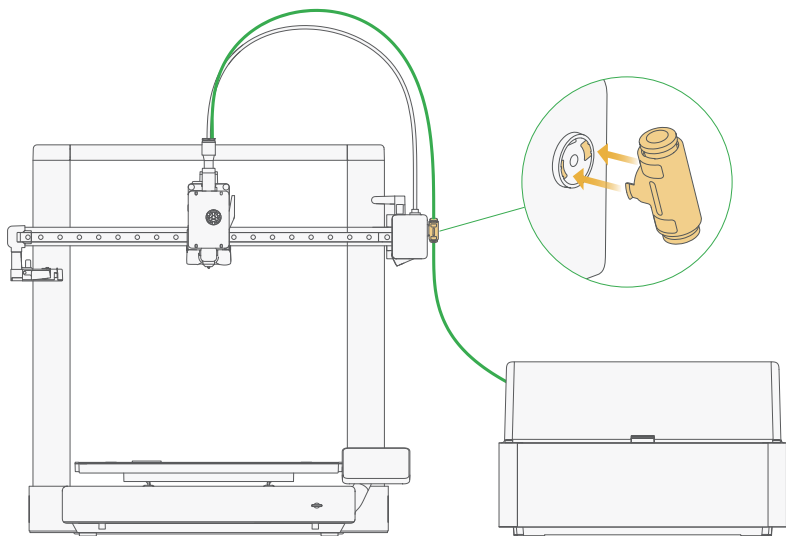

Using the PTFE tube coupler, the A2L can be directly connected to a single AMS, AMS 2 Pro, and AMS HT. For connecting multiple AMS units or different AMS models, visit [bambulab.com/a2l-ams-connection](https://www.bambulab.com/a2l-ams-connection) for detailed guidance.

21. Install the External Spool (for Non-AMS Use Case)

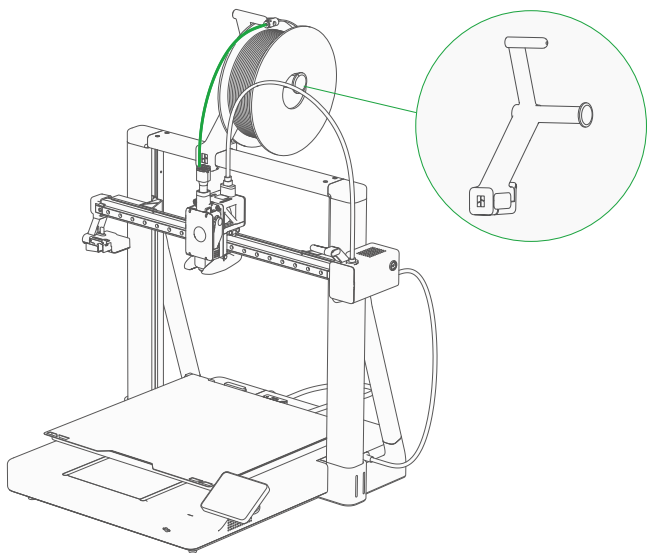

- 1) Install the spool holder.
- 2) As shown in the figure, use a PTFE tube to connect any filament inlet on the toolhead.
- 3) Hang a spool of filament on the spool holder. Then, insert the filament into the PTFE tube and keep pushing it until it enters the extruder and cannot move forward.

22. Plug in the Power Cable and Power On

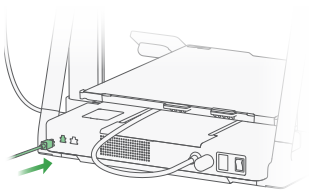

- 1) Plug the AMS lite 4-pin connector into the port on the back of the printer.

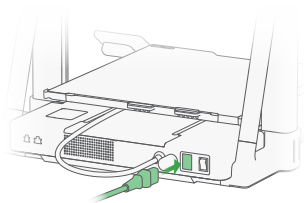

- 2) Plug in the power cable and turn on the printer using the power switch on the back.

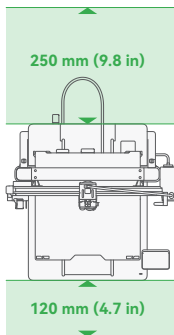

- 3) Please leave a safety clearance : 250 mm at the back and 120 mm at the front.

Warning: Ensure cables are not tangled or crossed, as this may affect the normal operation of the device.

23. Network Setting

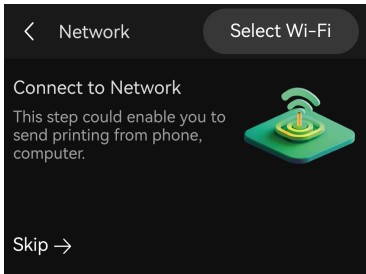

- 1) Follow the instructions until you see this screen. Tap "Select Wi-Fi" to search for available network.

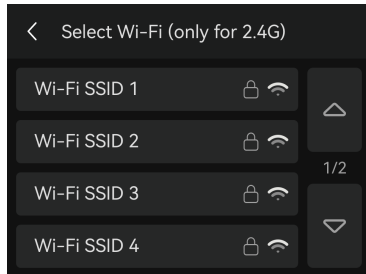

- 2) Select your preferred network.

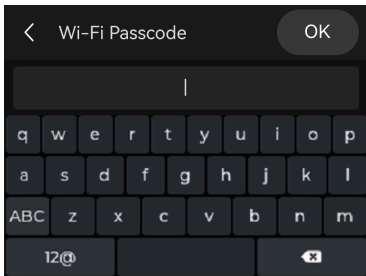

- 3) Input the passcode, and then tap "OK".

24. Bind the Printer - Bambu Handy

- 1) Scan the QR code on the right to download Bambu Handy. Register and log in to your Bambu Lab account.
- 2) Follow the instructions on the screen until a QR code appears.
- 3) Scan the QR code on Bambu Handy to bind the printer to your Bambu Lab account.

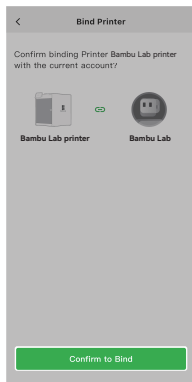
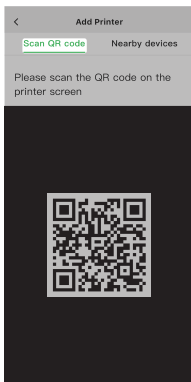
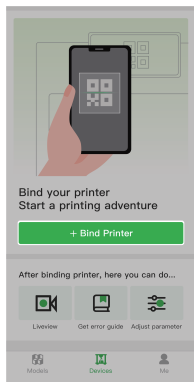
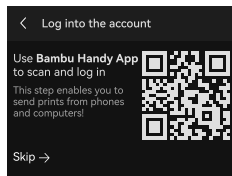

- 4) Follow the instructions on the screen to complete the initial calibration. It is normal to have vibration and noise during the process.

25. Bind the Printer - Bambu Studio

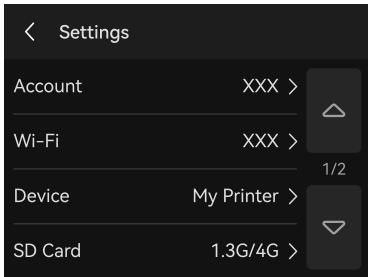

- 1) Connect both the computer and printer to the same wireless network, and do not use a guest network that has network device separation enabled.

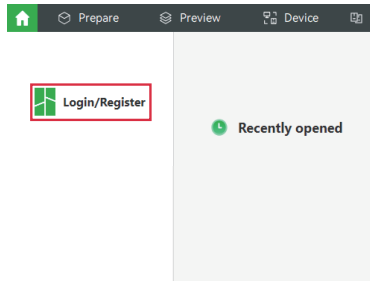
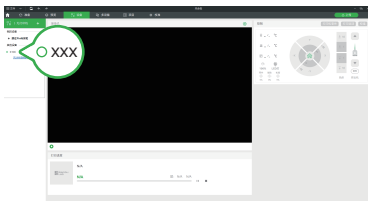

- 2) Visit the link below to download and install Bambu Studio. Register and log in to your Bambu Lab account.
bambulab.com/download/studio

- 3) Click "+" on the device page, and Bambu Studio automatically discovers printers on the same network. Click the detected printer to bind it to your Bambu Lab account.

26. Load Filament Spool on AMS lite

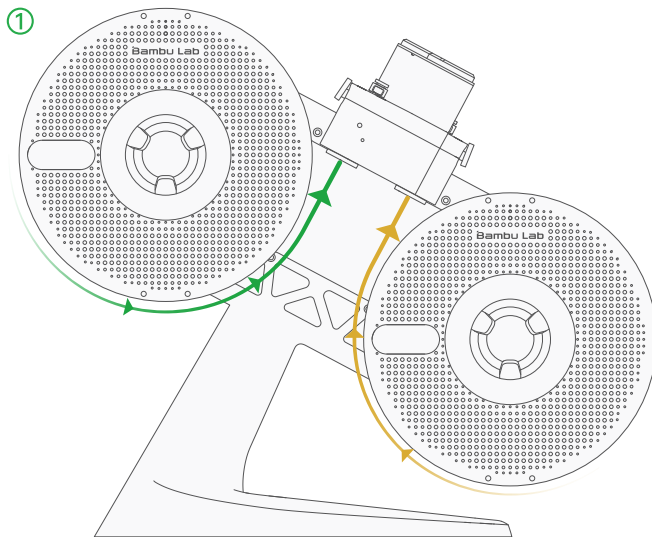

- 1) Orient the spools according to the filament winding direction, as shown in the diagram.

26. Load Filament Spool on AMS lite

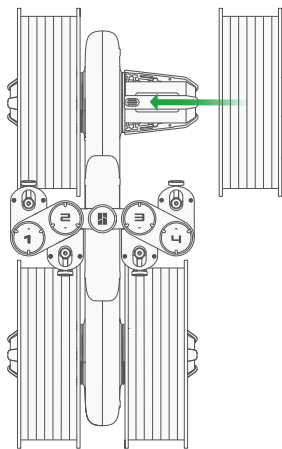

②

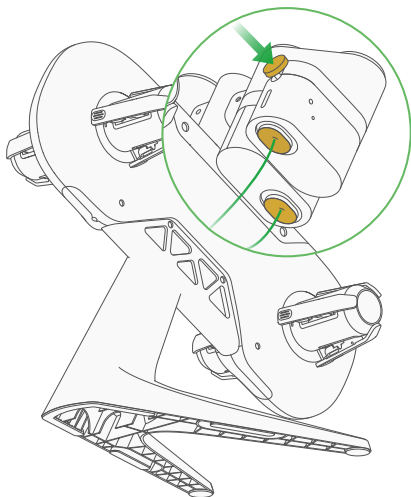

③

- 2) Push the spool all the way onto the rotary spool holder. Make sure it fully clicks into place.
- 3) Keep pressing the release button and manually feed the filament into the filament inlet until the AMS lite starts pulling it.

Note: If the filament gets stuck before entering the extruder, press the release button to remove it.

27. First Print



- 1) Tap "Print Files" to access the pre-loaded models on the SD card.



- 2) Select the model you want to print.

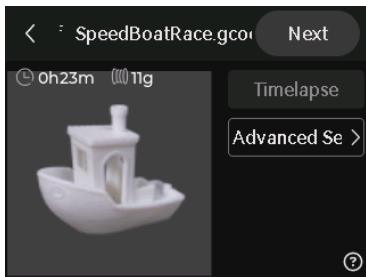

- 3) Turn on "Timelapse" for timelapse video recording.

Turn on or off other options as needed in "Print Options".

28. After-Print Notes



Wait until the build plate fully cools down to remove prints.

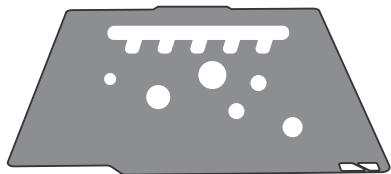

Wash the build plate regularly with hot water and detergent for best adhesion.

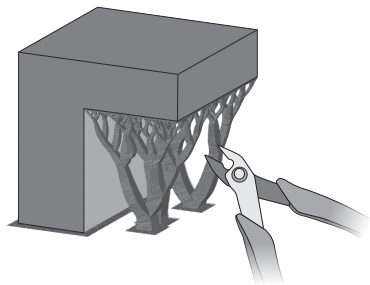

If there is a support structure used, remove it as soon as possible after taking out the print. It will be harder to remove if the filament absorbs moisture.

29. Regular Maintenance

A 3D printer has a complex mechanical structure and numerous moving parts. Regular maintenance is essential to ensure stable operation and high-quality prints.

Metal Moving Parts:

- Regularly lubricate the rails, guide rails, idler wheels, lead screws, and extruder wheel assembly to prevent rust.
- Use lubricant oil for the X-axis rail, Y-axis guide rail, and idler wheels, while the lead screws and extruder wheel assembly should be lubricated with grease.

Consumables:

- Regularly check for aging (including deformation) and wear on components such as plastic or rubber parts and filament cutter.
- Replace parts as necessary, for example, the heatbed nozzle wiper and PTFE tubes.

Other Components:

- Check camera lenses, fans, and filament sensors for dust or debris.
- Regularly clean the fans; gently wipe the camera with a non-woven cloth moistened with anhydrous alcohol or isopropanol to ensure optimal clarity.



Please refer to the "Regular Maintenance Recommendations" section on our wiki bambula-b.com/support/maintenance for more information.

30. Printer Specifications

Technology	
Type	Fused Deposition Modeling
Body	
Build Volume (W*D*H)	330*320*325 mm
Chassis	Aluminum and Steel
Outer Frame	Plastic
Dimensions and Weight	
Physical Dimensions	544*529*505 mm
Net Weight	12.8 kg
Toolhead	
Extruder Gear	Hardened Steel
Nozzle	Stainless Steel
Max Nozzle Temperature	300 °C
Supported Nozzle Diameter	0.2 mm, 0.4 mm, 0.6 mm, 0.8 mm
Filament Cutter	Built-in
Filament Diameter	1.75 mm
Extruder Motor	Servo Extruder Motor
Heatbed	
Build Plate Material	Flexible Steel Plate
Included Build Plate Type	Textured PEI Plate
Supported Build Plate Type	Textured PEI plate, Engineering Plate, Cool Plate Super-Tack
Max Heatbed Temperature	80 °C
Speed	
Max Speed of Toolhead	500 mm/s
Max Acceleration of Toolhead	10 m/s ²

30. Printer Specifications

Max Flow for Hotend	28 mm ³ /s (Test parameters: 150 mm round model with a single outer wall; Bambu Lab PLA Basic; 220 °C printing temperature)
Cooling	
Part Cooling Fan	Closed Loop Control
Hotend Cooling Fan	Closed Loop Control
Supported Filament Type	
PLA, PETG, TPU, PVA	Suitable for Printing
PLA-CF, PETG-CF	Suitable for Printing (Replace with Hardened Steel Nozzle)
Sensor	
Camera	Low-frame-rate camera, up to 1080P, supports time-lapse photography
Filament Run Out Sensor	Supported
Filament Tangle Sensor	Supported
Filament Odometry	Supported
Power Loss Recovery	Supported
Clumping Detection	Supported
Electrical Requirements¹⁾	
Voltage	High-voltage Version: 200-240 VAC, 50/60 Hz Low-voltage Version: 100-120 VAC, 50/60 Hz
Max Power ²⁾	High-voltage Version: 1000 W@220 V Low-voltage Version: 1000 W@110 V
Environment Requirement	
Operating Temperature	15-30 °C
Electronics	
Touchscreen	3.5 inch, 240*320 Touchscreen

30. Printer Specifications

Storage	MicroSD Card
Control Interface	Touchscreen, mobile App, PC App
Motion Controller	Single-core Cortex-M4 Processor & Single-core Cortex-M7 Processor
Communication	Wi-Fi, Bambu-Bus
Software	
Slicer	Bambu Studio Supports third-party slicers which export standard G-code, such as Super Slicer, PrusaSlicer and Cura, but certain advanced features may not be supported.
Supported Operating System	MacOS, Windows, Linux
Network Control	
Ethernet	Not Available
Wireless Network	2.4G Wi-Fi
Network Kill Switch	Not Available
Removable Network Module	Not Available
802.1X Network Access Control	Not Available
Wi-Fi	
Operating Frequency	<ul style="list-style-type: none">• 2412 - 2472 MHz (CE/MIC)• 2412 - 2462 MHz (FCC)• 2400 MHz - 2483.5 MHz (SRRC)
Wi-Fi Transmitter Power (EIRP)	≤ 30 dBm (FCC), ≤ 20 dBm (CE/SRRC)
Wi-Fi Protocol	IEEE 802.11 b/g/n

1) The printer's voltage specifications vary by sales region. Before use, check the label next to the power socket to ensure the supply voltage matches the indicated voltage.

2) To ensure the heated bed quickly reaches the needed temperature, the printer will maintain maximum power for about 3 minutes.

31. AMS lite Specifications

Body	
Dimensions	397*208*342 mm
Net Weight	1.6 kg
Housing Material	Plastic
Printing	
Filament Supported	PLA, PETG, ABS, ASA, PET, PA, PVA (dried), BVOH (dried), PP, POM, HIPS, Bambu PLA-CF/PAHT-CF/PETG-CF/Support for PLA/PETG and TPU for AMS
Filament Not Supported	TPE, generic TPU, PVA (damp), BVOH (damp), Bambu PET-CF/TPU 95A, and other filament that contains carbon fiber or glass fiber
Filament Diameter	1.75 mm
Spool Dimension	Width: 40 mm-68 mm Inner Diameter: 53 mm-58 mm
RFID Identification	Supported
Power	
Input	Power can only be supplied via Bambu-Bus, 24 VDC

32. Technical Support

If you need technical support, please follow any of the following methods:

Method 1: Visit the Bambu Lab Wiki for tutorials and maintenance guidance.

wiki.bambulab.com/home



Method 2: Get in touch through one of the options listed in the Contact Us section of our Support Center.

bambulab.com/support



Method 3: Create a support ticket on Bambu Handy, from the Support Center section.

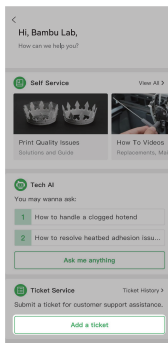
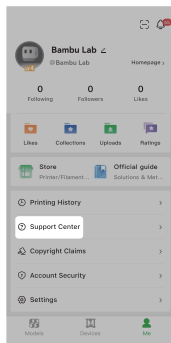



Bambu Lab

www.bambulab.com

